

MOVANO 4X4 – Approved Conversion

European Whole Vehicle Type Approval e1*2007/46*1191*00



The Vauxhall Movano 4X4 conversion from specialist converter Oberaigner offers the perfect solution when conditions prove just too much for a single-driven axle. Developed for a wide range of vehicle applications such as fire and rescue, police and military, forestry and utility companies plus numerous professional applications, the conversion is fully approved by the Vauxhall Special Vehicle Engineering team and is covered by European Whole Vehicle Type Approval.



Vauxhall approved conversions

These conversions have been tested to ensure they meet the technical standards required by General Motors UK Limited.

Movano 4X4 panel vans, chassis cabs plus tipper and dropside core conversions
EC WVTA e1*2007/46*1191*00.

Key selling points

- › Switchable All-Wheel Drive (AWD) for use under poor road conditions and off-road driving
- › Additional weight kept to a minimum by use of lightweight components
- › Minimal vehicle lift due to compact AWD system
- › Switchable 1:1.42 gearing ratio (Terrain gear) with fascia-mounted control panel for AWD system
- › Extensive use of existing components helps to reduce conversions costs
- › Standard servicing requirements through the Vauxhall retail network
- › Two-year/75,000 miles conversion warranty

Typical conversion features

- › New front axle
- › Driveline adaptation featuring new prop shaft, joint transfer case and front axle drive
- › Lengthwise locking rear differential
- › New engine cross member
- › 90-litre fuel tank and replacement/re-routed fuel lines
- › Extended fuel filler flap
- › Raised chassis frame with additional mounting brackets, spring strut adaptations, shock absorber fixings and spacing blocks
- › 65mm increased ground clearance

Please note

Typical conversion examples shown. Conversions on other model variants are available please consult the converter. Full specification, option and colour availability details of the Movano range appear in the Movano brochures available from your Vauxhall retailer or Lo-call 0845 6001500. Alternatively, details can be found on our website at www.vauxhall.co.uk/vans



OBERAIGNER
GmbH

With over 20 years' experience in the design and production of 4X4 conversions, the Oberaigner Group is one of the leading suppliers of off-road vehicles in this sector of the commercial vehicle market. Designed and manufactured to the most exacting standards, their products are marketed worldwide and are also supported by the very best in technical support and service.

Converter contact details:

For conversion pricing, option and warranty details contact:
Thomas Wendschuh, Oberaigner Automotive GmbH, Roman-Oberaigner-Allee 1, 18299 Laage, Germany
Email: thomas.wendschuh@oberaigner.com Website: www.oberaigner.com Tel: +49 38454 3290-280

The Oberaigner conversion has also been designed to ensure the Movano range maintains its impressive load carrying abilities. Utilising lightweight and compact switchable AWD components specifically designed and manufactured for the Movano by Oberaigner has resulted in a weight increase of only 150kg with an increase in ground clearance of 65mm.

Servicing requirements are exactly the same as standard Movano models and can be carried out through the Vauxhall Commercial Vehicle retail network. Direct technical support can also be provided by Oberaigner if required and the conversion itself is supported by a separate two-year/75,000 mile warranty.



The specifically designed, lightweight AWD components ensure that the Movano maintains its load carrying potential. L3 H2 R3500 HD panel van model illustrated.



The operation of the AWD system is controlled via a fascia button and fascia display that ensures it's simple to switch between RWD and AWD as driving conditions demand. In AWD mode the ESP and ABS systems are disconnected. Operation of the ignition switch restores the ESP and ABS once the AWD system is de-activated.



The Oberaigner 4x4 conversion is available with a variety of power outputs of the Movano 2.3CDTI 16v diesel engine.



As well as the standard AWD driving mode there is also a low-range mode when more difficult driving conditions prevail such as pulling away under load in tricky off-road conditions. Although the AWD system can also be deployed when driving on harsh road conditions, long term on-road driving with the AWD system engaged is not recommended due to the standard fitment of the lengthwise locking rear differential, transfer case and front axle.

Dimensions shown in mm (inches). Heights shown unladen.

Panel van
L3 H2 R3500 HD

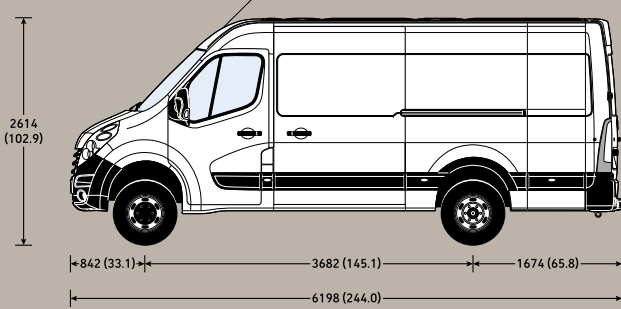

Crew cab tipper
L3 H1 R4500 HD

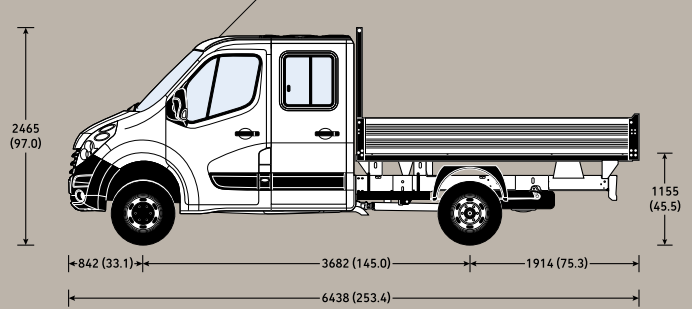

The Oberaigner conversion can be carried out on all RWD Movano panel vans. L3 H2 R3500 HD model illustrated.

The Oberaigner 4X4 conversion is offered on all RWD L3 and L4 variants for panel van, doublecab, chassis or crew cab models, plus all RWD L2 H1 chassis or crew cab models. Both 3500 and 4500 GVW ratings are available. The conversion can also be specified for the respective tipper and dropside core conversions.



The conversion also extends to RWD Movano chassis and crew cabs including the tipper and dropside core conversions. L3 H1 R4500 HD crew cab tipper model illustrated.

Weights* kg for example models

Model	UK plated weights and kerbweights				
	Front axle	Rear axle	GVW	Kerb	Payload
Movano L3 H2 R3500 HD panel van	1850	2300	3500	2396	1104
Movano L3 H1 R4500 HD crew cab tipper	1850	3200	4500	2989	1511

***Please note:** Typical examples shown above. **Kerbweights** include conversion body weight, coolant, oil, 90% full fuel tank and spare wheel. They will vary according to the vehicle specification (including options and accessories) with a corresponding variation in payload. **Payload** figures do not allow for the weight of the driver, or any passengers, which should therefore be deducted from the figures shown. **Gross plated weights** (including axle weights) quoted on the vehicle plated must never be exceeded.

Every effort has been made to ensure that the contents of this publication were accurate and up-to-date at the time of publication (April 2014). Vauxhall vehicles are equipped with components manufactured by various General Motors operating units and outside suppliers. The Company reserves the right to alter specifications and withdraw products from sale without notice. Any such alterations will be notified to Vauxhall retailers at the earliest opportunity; please consult your local retailer for the latest information. The specifications detailed within this brochure are not necessarily applicable to alternative models such as Special Editions. Details of any such models will be contained in specific literature or found on the Vauxhall website. Please note that Vauxhall retailers are not the agents of General Motors UK Limited and are not authorised to bind the Company by any specific or implied undertaking or representation. It is advisable to ensure that your motor insurance policy provides adequate cover for additional fitted options and accessories. Please note accessories shown are for illustrative purposes only. All rights reserved. No part of this publication may be reproduced in any form or by any means, without the prior written permission of General Motors UK Limited.

V1 ©2014 General Motors UK Limited Published April 2014 General Motors UK Limited, Luton LU1 3YT



COMMERCIAL VEHICLES
The Wheels of Business

VAUXHALL