

# MOVANO Maxi-Low Luton Van – Recognised Conversion

National Small Series Type Approval e11\*NKS\*1556\*00



The Platform Cab-based Vauxhall Movano Maxi-Low Luton Van features a high payload, large capacity and a safe easy exit for loading and unloading. For both fleet manager and owner-driver this allows more delivery drops (or collections) during an operational cycle, hence increasing the profit opportunity.

The body is manufactured from a lightweight construction of fully recyclable plastic honeycomb panels that results in a payload of almost 1500kg and capacity of 20.0cu.m (706cu.ft). The 600mm load floor height together with the 400mm rear step means there is no need for a heavy tail lift and the aerodynamic canopy reduces drag helping to improve fuel economy. Standard features include: roller shutter rear door, anti-slip floor, opalescent glass-fibre roof panel for improved load area visibility, useful over-cab internal storage facility and load area light.

In addition to the standard Luton Van, Maxi-Low will also offer a walk-through multi-drop variant designed for parcel delivery and a larger Jumbo Luton Van with capacity of 26.0cu.m (918cu.ft).



L3 H1 Maxi-Low Luton Van.



Roller shutter rear door.



Low rear step height – 400mm.

## Key selling points

- › Impressive payload – 1496kg
- › Low rear step height – 400mm
- › Low loading height – 600mm
- › No Operator's licence required

## Vauxhall recognised conversions

These conversions have been tested to ensure they meet the technical standards required by General Motors UK Limited.

## Typical conversion features

- › Lightweight and durable body constructed from recyclable polypropylene
- › Roller shutter rear door
- › Opalescent glass-fibre roof panel
- › Load area light
- › Anodised aluminium framework with galvanised back frame
- › Slip-resistant floor
- › Aerodynamic canopy and front pillars reduce drag and improve fuel economy
- › Body colour-coded to match cab
- › Integrated wheel arch reduces spray during wet weather

## Conversion options (at extra cost)

- › Electro-magnetic rear door locking systems
- › Motion sensor load area lighting
- › Metallic paint
- › Heavy-duty floor covering
- › Rear parking distance sensors
- › Full-length aluminium lashing rails
- › Conventional twin rear doors
- › Rear-view camera with cab monitor

## Please note

Typical conversion examples shown. Conversions on other model variants are available please consult the converter. Full specification, option and colour availability details of the Movano range appear in the Movano brochure available from your Vauxhall retailer or Lo-call 0845 600 1500. Alternatively, details can be found on our website at [www.vauxhall.co.uk/vans](http://www.vauxhall.co.uk/vans)



## Converter contact details:

For conversion pricing, option and warranty details contact:  
Maxi-Low, 18A Regent Street Industrial Estate, Leicester LE19 2DT  
Email: [info@maxi-low.co.uk](mailto:info@maxi-low.co.uk) Website: [www.maxi-low.co.uk](http://www.maxi-low.co.uk) Tel: 0870 034 5505

Designed by Maxi-Low and manufactured by Allfleet Bodyshop Services from their brand new purpose-built facility in Loughborough. Established in 2014, the new partnership is dedicated to providing continued engineering and product development. This commitment will not only ensure outstanding quality and value-for-money but excellent customer satisfaction.

**Dimensions mm (inches).** Height shown unladen.

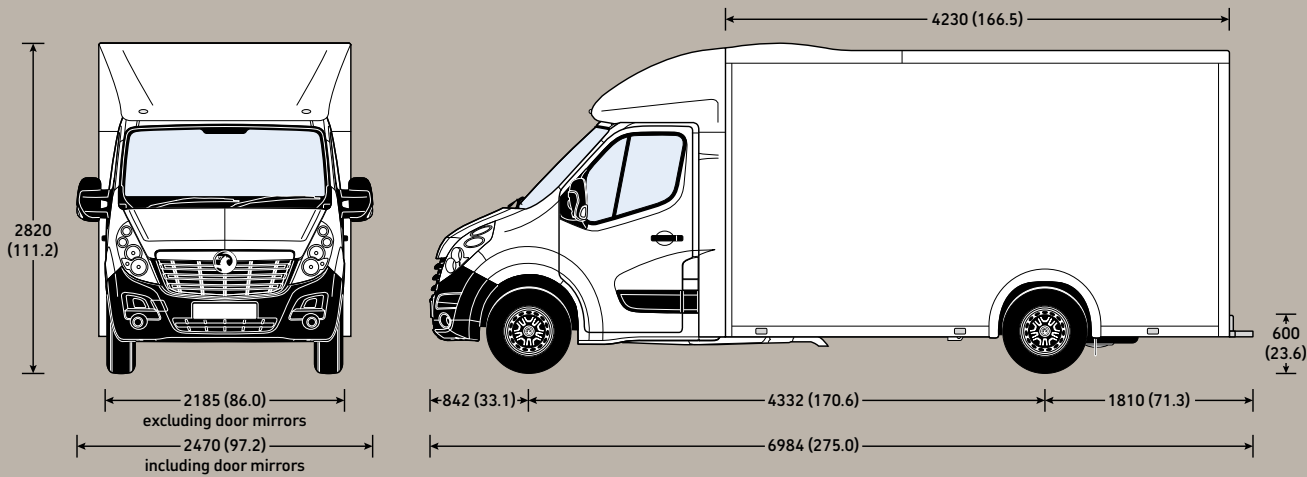

**Load area dimensions mm (inches)**

	L3
Maximum length	4230 (166.5)
Maximum width	2054 (80.9)
Maximum height	2185 (86.0)
Width between wheel arches	1325 (52.2)
Loading height	600 (23.6)
Loadspace volume cu.m (cu.ft.)	20.0 (706)



*Aerodynamic canopy aids fuel economy.*



*Rear access grab handle.*



*Opaque glass-fibre roof panel with load area light.*



*Useful over-cab storage facility.*



*Optional rear-view camera.*

**Weights\* kg for Maxi-Low Luton Van**

Model	UK plated weights and kerbweights				
	Front axle	Rear axle	GVW	Kerb	Payload
L3 H1 F3500 2.3CDTi 16v (125PS)	1850	2100	3500	2074	1426

\*Please note: **Kerbweight** includes conversion body weight, coolant, oil, 90% full fuel tank and spare wheel. It will vary according to the vehicle specification (including options and accessories) with a corresponding variation in payload. **Payload** figure does not allow for the weight of the driver, or any passengers, which should therefore be deducted from the figure shown. **Gross plated weight** (including axle weights) quoted on the vehicle plated must never be exceeded.

Every effort has been made to ensure that the contents of this publication were accurate and up-to-date at the time of publication (October 2014). Vauxhall vehicles are equipped with components manufactured by various General Motors operating units and outside suppliers. The Company reserves the right to alter specifications and withdraw products from sale without notice. Any such alterations will be notified to Vauxhall retailers at the earliest opportunity, please consult your local retailer for the latest information. The specifications detailed within this brochure are not necessarily applicable to alternative models such as Special Editions. Details of any such models will be contained in specific literature or found on the Vauxhall website. Please note that Vauxhall retailers are not the agents of General Motors UK Limited and are not authorised to bind the Company by any specific or implied undertaking or representation. It is advisable to ensure that your motor insurance policy provides adequate cover for additional fitted options and accessories. Please note accessories shown are for illustrative purposes only. All rights reserved. No part of this publication may be reproduced in any form or by any means, without the prior written permission of General Motors UK Limited.

V1 ©2014 General Motors UK Limited Published October 2014 General Motors UK Limited, Luton LU1 3YT



**COMMERCIAL VEHICLES**  
*The Wheels of Business*

**VAUXHALL**